

# C3-470B Jnavi SPECSHEET

<b>MODEL NAME</b>	<b>GR – C3-470B - XXXX - T - P</b>	
<b>CODE NO.</b>		
<b>CUSTOMER MODEL NAME</b>	<b>C3-470B</b>	
<b>INVESTIGATION</b>	<b>INSPECTION</b>	<b>APPROVAL</b>
200 . . .	200 . . .	200 . . .

2005. . .

## **Contents**

### **1. Functional Description**

- 1.1 Features
- 1.2 Block Diagram
- 1.3 Receiver Unit Specifications
- 1.4 Protocols

### **2. Interface Specification**

- 2.1 Pin Description
- 2.2 I/O Pin Command Level
- 2.3 Serial Interfaces (**User programmable setting command**)

### **3. Electrical Specification**

- 3.1 Absolute Maximum Ratings
- 3.2 Operating Conditions
  - 3.2.1 DC Characteristics
  - 3.2.2 AC Characteristics
  - 3.2.3 RF Input Impedance

### **4. Performance Specification**

- 4.1 3D Tracking Sensitivity (Level Decrease)
- 4.2 3D Re-Tracking Sensitivity (Level Increase)
- 4.3 Temperature & Sensitivity

### **5. Mechanical Dimension & Pin Description**

### **6. Packing Description**

**1. Functional Description**

**1.1 Features**

Fully self-contained GPS receiver

Fully shield

Full implementation of SiRFstar™III GPS architecture

- GSC3F(High Performance GPS Single Chip)  
GPS DSP with integrated real time clock(RTC) ARM7TDMI CPU
- 4Mbit FLASH memory
- Low noise amplifiers and SAW filters.
- TCXO, Reset & Regulator etc
- Built-In Back-up Battery
- GPS receiver With Patch Antenna
- Patch Antenna Size : 35(w)mm X 35(d)mm X 3(h)mm
- Max. Size : 39.0(w)mm X 35.5(d)mm X 8.0(h)mm
- Weight : 21 grams

**1.2 Block Diagram**

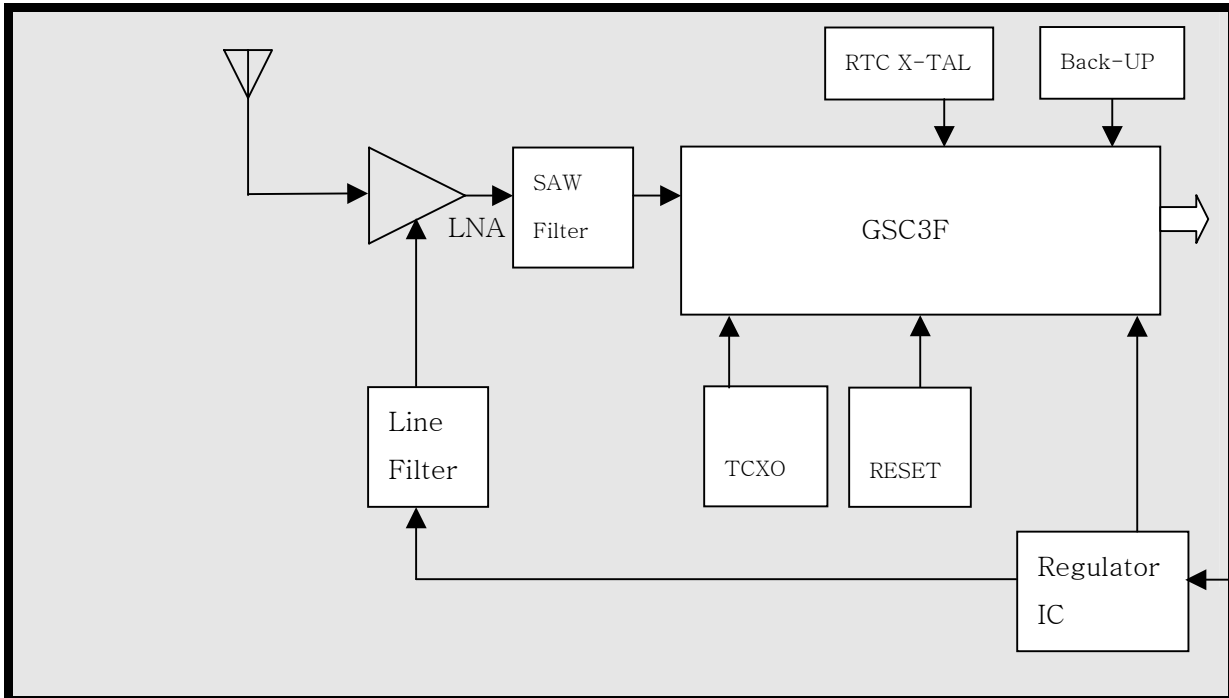

### 1.3 Receiving Unit Specifications

Receiver type	: L1 frequency, C/A Code, 20-channel
Max up-date rate	: 1 sec
Accuracy (SA off)	: Position < 10m 3DRMS
3D Tracking Sensitivity	: -156dBm at the receiver input(typical)
Operational Limits	: Altitude < 18,000m (60,000ft) Velocity < 515m/s (1,000knots)

#### Time To First Fix (TTFF)

##### a) Cold Start 60sec (typical)

In a 'Cold Start' scenario, the receiver has no knowledge of position, time or the satellite constellation. The receiver starts to search for signals blindly.

Cold start time is the longest startup for this module

##### b) Warm Start 40sec (typical)

In a 'Warm Start' scenario, due to a backup battery the receiver knows its last position, the approximate time and the constellation almanac.

Thanks to this it can quickly acquire satellites and get a position fix faster than in 'Cold Start' mode.

##### c) Hot Start < 3sec (typical)

In a 'Hot Start' scenario, the receiver has been powered off for less than 2 hours since the last valid navigation solution. The GPS uses its last Ephemeris data to calculate a position fix.

Re-acquisition time 5sec typical (within 60sec GPS signal obstruction)

### 1.4 Protocols

NMEA 0183 (default) 9600bps

Activated message : GGA,GSA,GSV, RMC all with checksum enabled

**User programmable setting for baud rate, NMEA & Interval time  
by user define message setting Command. (see 2.3 Serial Interface Setting)**

## ***Output Messages***

Table 1-1 lists each of the NMEA output messages specifically developed and defined by SiRF for use within SiRF products.

*Table 1-1 NMEA Output Message*

<b>Option</b>	<b>Description</b>
GGA	Time, position and fix type data.
GLL	Latitude, longitude, UTC time of position fix and status.
GSA	GPS receiver operating mode, satellites used in the position solution, and DOP values.
GSV	The number of GPS satellites in view satellite ID numbers, elevation, azimuth, and SNR values
RMC	Time, date, position, course and speed data.
VTG	Course and speed information relative to the ground.
150	OK to send message.

A full description and definition of the listed NMEA messages are provided by the next sections of this chapter.

Table 1-2 provides a summary of supported SiRF NMEA output messages by the specific SiRF platforms.

*Table 1-2 Supported NMEA*

<b>Message</b>	<b>SiRF Software Options</b>
GGA	Yes
GLL	Yes
GSA	Yes
GSV	Yes
RMC	Yes
VTG	Yes

**GGA –Global Positioning System Fixed Data**

Table 1-3 contains the values for the following example:

\$GPGGA, 161229,487,3723,2475,N,12158,3416,W,1.07,1.0,9.0,M...0000\*18

Table 1-3 GGA Data Format

Name	Example	Units	Description
Message ID	\$GPGGA		GGA protocol header
UTC Time	161229,487		hhmmss,sss
Latitude	3723,2475		ddmm,mmmm
N/S Indicator	N		N-north or s-south
Longitude	12158,3416		dddmm,mmmm
E/W Indicator	W		E=east or W=west
Position Fix Indicator	I		See Table 1-4
Satellites Used	07		Range 0 to 12
HDOP	1.0		Horizontal Dilution of Precision
MSL Altitude	9.0	Meters	
Units	M	Meters	
Geoid Separation		Meters	
Units	M	Meters	
Age of Diff. Corr.		Second	Null fields when DGPS is not used
Diff. Ref. Station ID	0000		
Checksum	*18		
<CR> <LF>			End of message termination

Table 1-4 Position Fix Indicator

Value	Description
0	Fix not available or invalid
1	GPS SPS Mode, fix valid
2	Differential GPS, SPS Mode, fix valid
3-5	Not supported
6	Dead Reckoning Mode, fix valid

---

Note – A valid position fix indicator is derived from the SiRF Binary M.I.D. 2position mode1

See the SiRF Binary Reference Manual

---

***GLL-Geographic Position-Latitude/Longitude***

Table 1-5 contains the values for following example:

\$GPGLL, 3723.2475,N,12158.3416,W,161229.487,A,A\*41

*Table 1-5 GLL Data Format*

<b>Name</b>	<b>Example</b>	<b>Units</b>	<b>Description</b>
Message ID	\$GPGLL		GLL protocol header
Latitude	3723.2475		ddmm.mmmm
N/S Indicator	N		N=north or S=south
Longitude	12158.3416		dddmm.mmmm
E/W Indicator	W		E=east or W=west
UTC Time	161229.487		hhmmss.sss
Status	A		A= data valid or V=data not valid
Mode	A		A=Autonomous, D=DGPS, E=DR
Checksum	*41		
<CR><LF>			End of message termination

**GSA-GNSSDOP and Active Satellites**

Table 1-6 contains the values for the following example:

\$GPGSA,A,3,07,02,26,27,09,04,15,,,,,,,,,1.8,1.0,1.5\*33

Table 1-6 GSA Data Format

Name	Example	Units	Description
Message ID	\$GPGSA		GSA protocol header
Mode 1	A		See Table 1-7
Mode 2	3		See Table 1-8
Satellite Used <sup>1</sup>	07		Sv on Channel 1
Satellite Used <sup>1</sup>	02		Sv on Channel 2
....			....
Satellite Used <sup>1</sup>			Sv on Channel 12
PDOP	1.8		Position Dilution of Precision
HDOP	1.0		Horizontal Dilution of Precision
VDOP	1.5		Vertical Dilution of Precision
Checksum	*33		
<CR><LF>			End of message termination

1. Satellite used in solution

Table 1-7 Mode 1

Value	Description
M	Manual-forced to operate in 2D or 3D mode
A	2Dautomatic-allowed to automatically switch 2D/3D

Table 1-8 Mode 2

Value	Description
1	Fix not Available
2	2D(<4SV's used)
3	3D(>3SV's used)



**GSV-GNSS Satellite in View**

Table 1-9 contains the values for the following example:

\$GPGSV,2,1,07,07,79,048,42,02,51,062,43,26,36,256,42,27,27,138,42\*71

\$GPGSV,2,2,07,09,23,313,42,04,19,159,41,15,12,041,42\*41

Table 1-9 GSV Data Format

<b>Name</b>	<b>Example</b>	<b>Units</b>	<b>Description</b>
Message ID	\$GPGSV		GSV protocol header
Number of Messages <sup>1</sup>	2		Range 1 to 3
Message Number <sup>1</sup>	1		Range 1 to 3
Satellites in View	07		
Satellite ID	07		Channel 1 (Range 1 to 32)
Elevation	79	degrees	Channel 1 (Maximum 90)
Azimuth	048	degrees	Channel 1 (True, Range 0 to 359)
SNR(c/No)	42	dBHz	Range 0 to 99, null when not tracking
....			....
Satellite ID	27		Channel 4 (Range 1 to 32)
Elevation	27	degrees	Channel 4 (Maximum 90)
Azimuth	138	degrees	Channel 4 (True, Range 0 to 359)
SNR(C/No)	42	dBHz	Range 0 to 99, null when not tracking
Checksum	*71		
<CR><LF>			End of message termination

1. Depending on the number of satellites tracked multiple messages of GSV data may be required.

**RMC-Recommended Minimum Specific GNSS Data**

Table 1-11 contains the values for the following example:

\$GPRMC,161229.487,A,3723.2475,N,12158.3416,W,0.13,309.62,120598,\*,\*10

Table 1-11 RMC Data Format

<b>Name</b>	<b>Example</b>	<b>Units</b>	<b>Description</b>
Message ID	\$GPRMC		RMC protocol header
UTC Time	161229.487		hhmmss.mmmm
Status	A		A=data valid or V=data not valid
Latitude	3723.2475		ddmm.mmmm
N/S Indicator	N		N=north or S=south
Longitude	12158.3416		ddmm.mmmm
E/W Indicator	W		E=east or W=west
Speed over Ground	0.13	knots	
Course over Ground	309.62	degrees	True
Date	120598		ddmmyy
Magnetic Variation		degrees	E=east or W=west
Checksum	*10		
<CR><LF>			End of message termination

1. A valid status is derived from the SiRF Binary. M.I.D 2 position mode 1. See the SiRF Binary Reference Manual.
2. SiRF Technology Inc. dose not support magnetic declination. All "course over ground" data are geodetic WGS84 directions.

***VTG-Course Over Ground and Ground Speed***

Table 1-12 contains the values for the following example:

\$GPVTG,309.62,T, ,M,0.13,N,0.2,K,A\*23

*table 1-12* VTG Data Format

<b>Name</b>	<b>Example</b>	<b>Units</b>	<b>Description</b>
Message ID	\$GPVTG		VTG protocol header
Course	309.62	degrees	Measured heading
Reference	T		True
Course		degrees	Measured heading
Reference	M		Magnetic <sup>1</sup>
Speed	0.13	knots	Measured Horizontal speed
Units	N		knots
Speed	0.2	km/hr	Measured horizontal speed
Units	K		Kilometers per hour
Mode	A		A=Autonomous, D=DGPS, E=DR
Checksum	*23		
<CR><LF>			End of message termination

1. SiRF Technology Inc. does not support magnetic declination. All “course over ground” data are geodetic WGS84 directions.

**2. Interface Specification**

**2.1. Pin Description**

Pin no	Name	Pin Description	I/O	Note
1	EN	Supply regulator enable	I	Open or low then enable 2.0v~VCC then disable
2	VCC(5.0V)	Supply Voltage	I	Used
3	TXA	Serial TX Port A	O	Used
4	RXA	Serial RX Port A	I	Used
5	GND	Ground		
6	BOOT	Module Boots Port 5.0V : Boot ON N.C : Boot OFF	I	Module boots into special debug Mode if VCC during reset

**2.2 I/O Pin Commend Level**

**RXA Input Level**

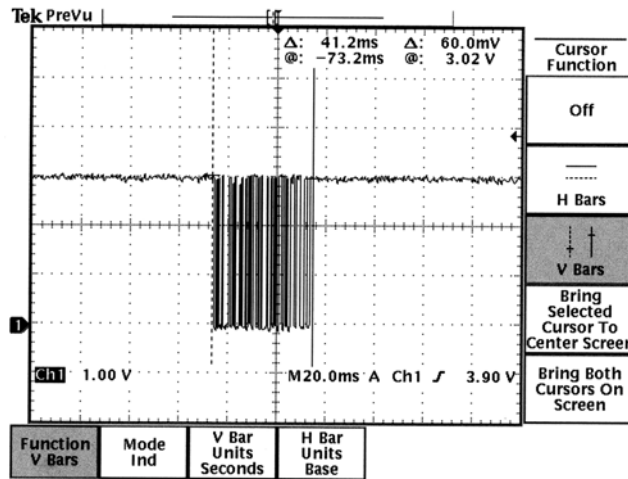

**TXA Output Level**

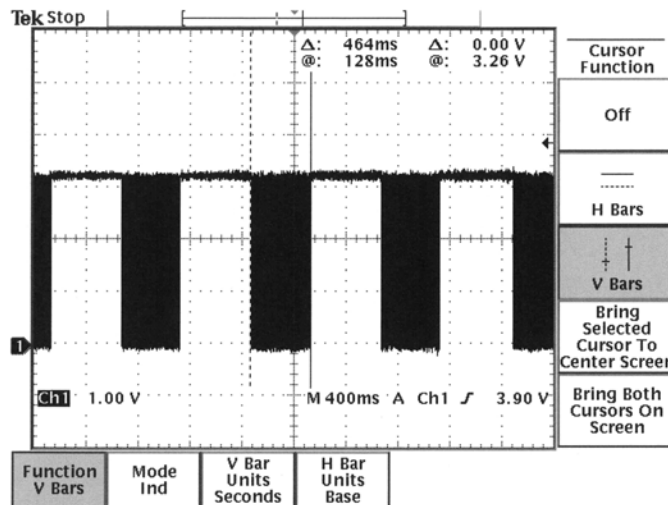

2.3 Serial Interfaces Setting

MESSAGE	COMMAND
COLD START	\$PSRF101,0,0,0,000,0,0,12,4*10
WARM START	\$PSRF101,0,0,0,000,0,0,12,2*16
HOT START	\$PSRF101,0,0,0,000,0,0,12,1*15
FACTORY RESET	\$PSRF101,0,0,0,000,0,0,12,8*1C

***Customer Define Message Setting Command***

Table 2.3 contains the values for the following example:

\$PSRF201,NMEA9600,NULL38400,GGA1,GLL0,GSA1,GSV1,RMC1,VTG0,USER0\*0D

2.3 Data Format Table

Name	Example	Units	Description
Message ID	\$PSRF		Protocol Header
	201		Measured heading
Protocol(Port A)	NMEA	Data Format	NULL,NMEA, Jcom(Customer Dependency)
Baudrate(Port A)	9600	bps	4800, 9600, 19200, 38400, 57600
Protocol(Port B)	NULL	Data Format	NULL, NMEA, Jcom(Customer Dependency)
Baudrate(Port B)	38400	bps	4800, 9600, 19200, 38400, 57600
GGA Interval Time	GGA1	sec	GGA Data Output Interval Time 1sec (0 ~ 10sec Selectable)
GLL Interval Time	GLL0	sec	GLL Data Output Off (0 ~ 10sec Selectable)
GSA Interval Time	GSA1	sec	GSA Data Output Interval Time 1sec (0 ~ 10sec Selectable)
GSV Interval Time	GSV1	sec	GSV Data Output Interval Time 1sec (0 ~ 10sec Selectable)
RMC Interval Time	RMC1	sec	RMC Data Output Interval Time 1sec (0 ~ 10sec Selectable)
VTG Interval Time	VTG0	sec	VTG Data Output Off(0 ~ 10sec Selectable)
USER Interval Time	USER0		Customer Option(Default 0)
Checksum	*0D		See Below* <sup>1</sup>
<CR><LF>			End of message termination

1. Checksum Delimiter and Field: \*hh

hh = The absolute value calculated by exclusive-OR'ing the 8 data bits (no start bits or stop bits) of each char in the Sentence, between, but excluding "\$" and "\*".

The hexadecimal value of the most significant and least significant 4 bits of the result are converted to two ASCII characters (0-9,A-F) for transmission.

The most significant character is transmitted first.

### 3. Electrical Specification

#### 3.1 Absolute Maximum Ratings

Parameter	Min	Max	Unit
Power supply voltage(VCC)	3.6	5.5	V
Serial port Input pin voltage	-0.3	5.0	V
Storage temperature	-20	+80	°C

**Warning – Stressing the device beyond the “Absolute Maximum Ratings” may cause permanent damage. These are stress ratings only. Operation beyond “Operating conditions” is not recommended and extended exposure beyond the “Operating condition” may affect device reliability.**

#### 3.2 Operating Conditions

##### 3.2.1 DC Characteristics ( Test Temperature : 25°C)

Parameter	Condition	Min	Typical	Max	Unit
Operating supply voltage	VCC	3.6	5.0	5.5	V
Operating supply ripple voltage				50	mV <sub>pp</sub>
Sustained supply current	VCC=5.0V	80	85	90	mA
Peak supply current	VCC=5.0V	85	90	95	mA
RXA TTL H Level	VCC=5.0V	2.1		VCC	V
RXA TTL L Level	VCC=5.0V	0		0.9	V
TXA TTL H Level	VCC=5.0V	2.1		2.8	V
TXA TTL L Level	VCC=5.0V	0		0.8	V
External Antenna Output Voltage	VCC=5.0V	2.7	2.8	2.9	V
External Antenna Output Current	VCC=5.0V	-	-	20	mA
Operating temperature *	VCC=5.0V	-20	+25	+60	°C

\* Operating Temperature

GPS DEVICE : -40°C ~ +80°C

BACK-UP BATTERY : -20°C ~ +60°C

(Lithium-Ion Rechargeable Battery)

##### 3.2.2 AC Characteristics

( Test Temperature : 25°C VCC = 5.0V Internal Antenna Input : Conducted )

Parameter	Condition	Min	Typical	Max	Unit
Tracking Sensitivity (C/N)	3D (C/N avg. 13dBHz)		-156		dBm
Re-acquisition Sensitivity (C/N)	3D (C/N avg. 16dBHz)		-153		dBm
Cold start Sensitivity (C/N)	3D (SV 9EA in view)		-135		dBm
Cold start time(TTFF)	-126 dBm(2D) (SV 9EA)		60		sec
Hot start time	-126 dBm(2D) (SV 9EA)		1		sec
Re-acquisition time (5 sec)	-126 dBm(3D) (SV 9EA)		3		sec
Re-acquisition time (60 sec)	-126 dBm(3D) (SV 9EA)		3		sec
Position error (Latitude, Longitude)	-126 dBm(SV 9EA in View)		10		m
Position error (Elevation)	-126 dBm(SV 9EA in View)		50		m

3.2.3 RF Input Impedance

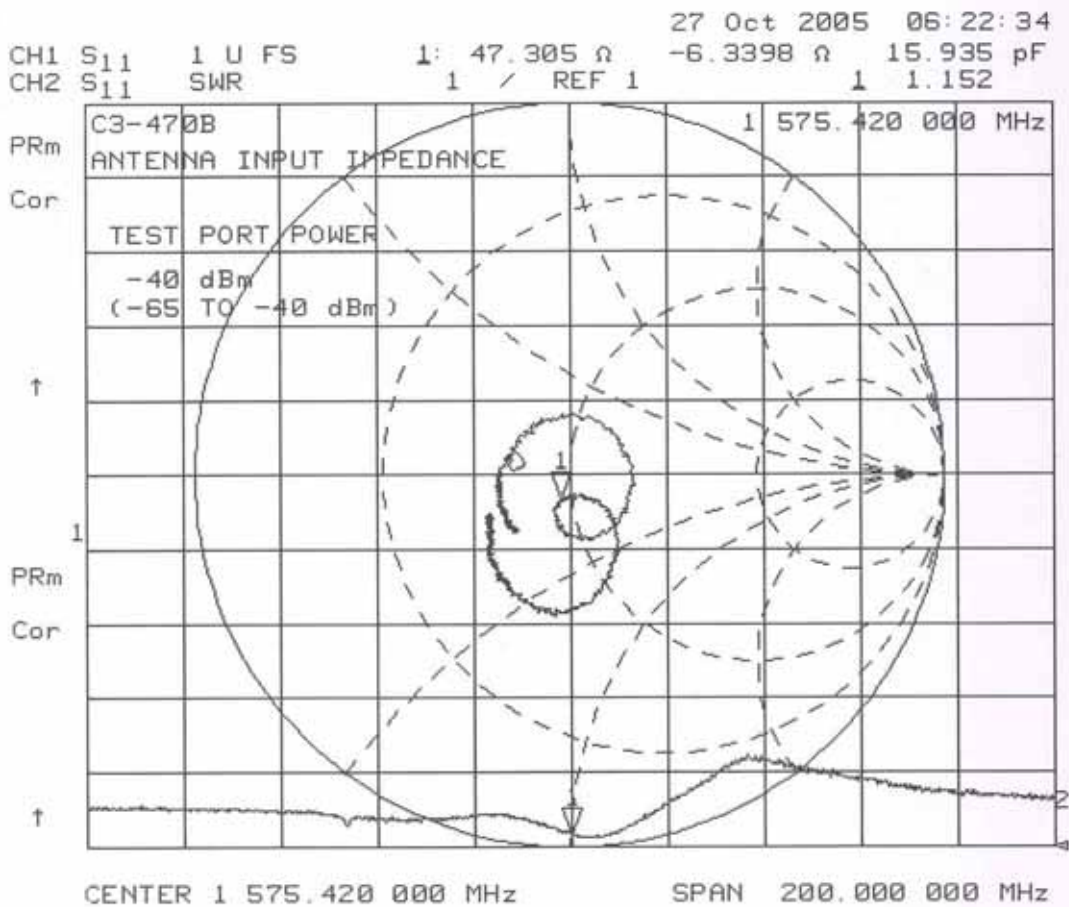

### 4 Performance Specification

#### 3D Tracking Sensitivity

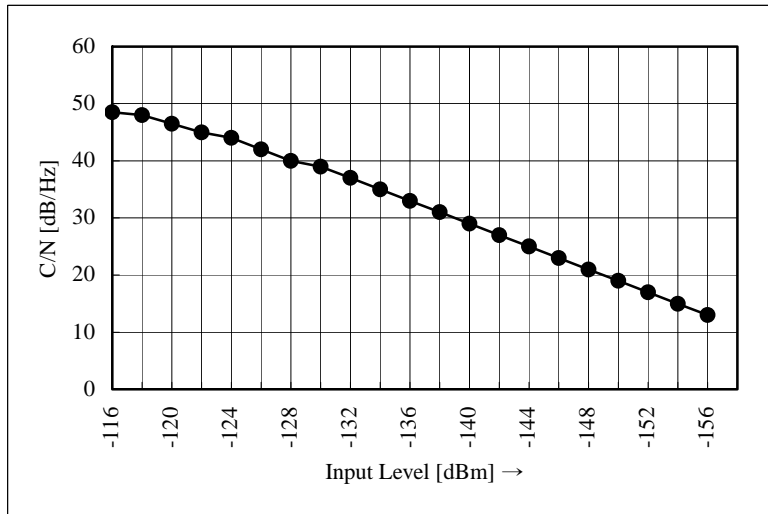

#### 3D Re-Tracking Sensitivity

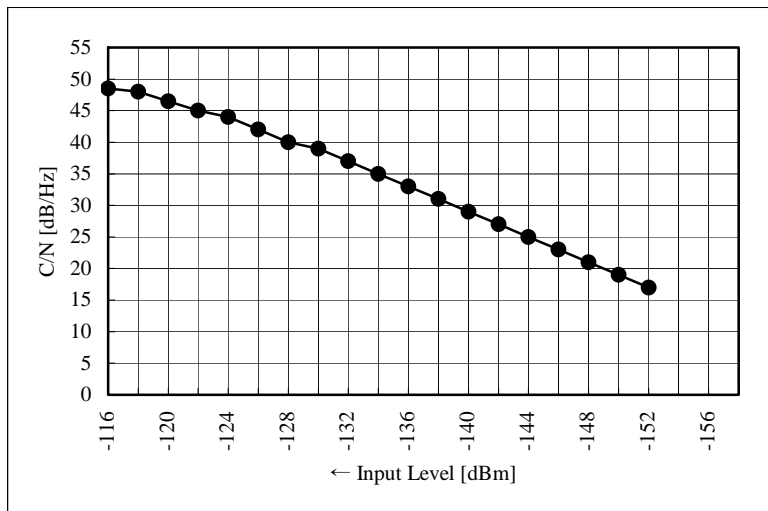

#### Temperature & Sensitivity (Input : -130dBm)

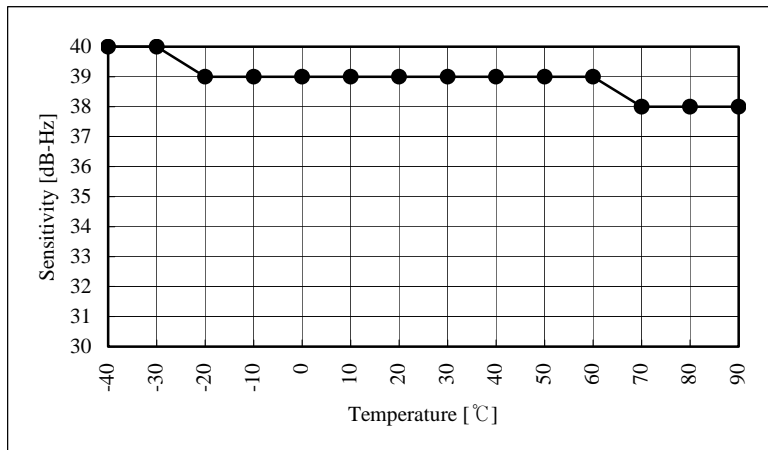



### 5. Mechanical Dimension & Pin Description

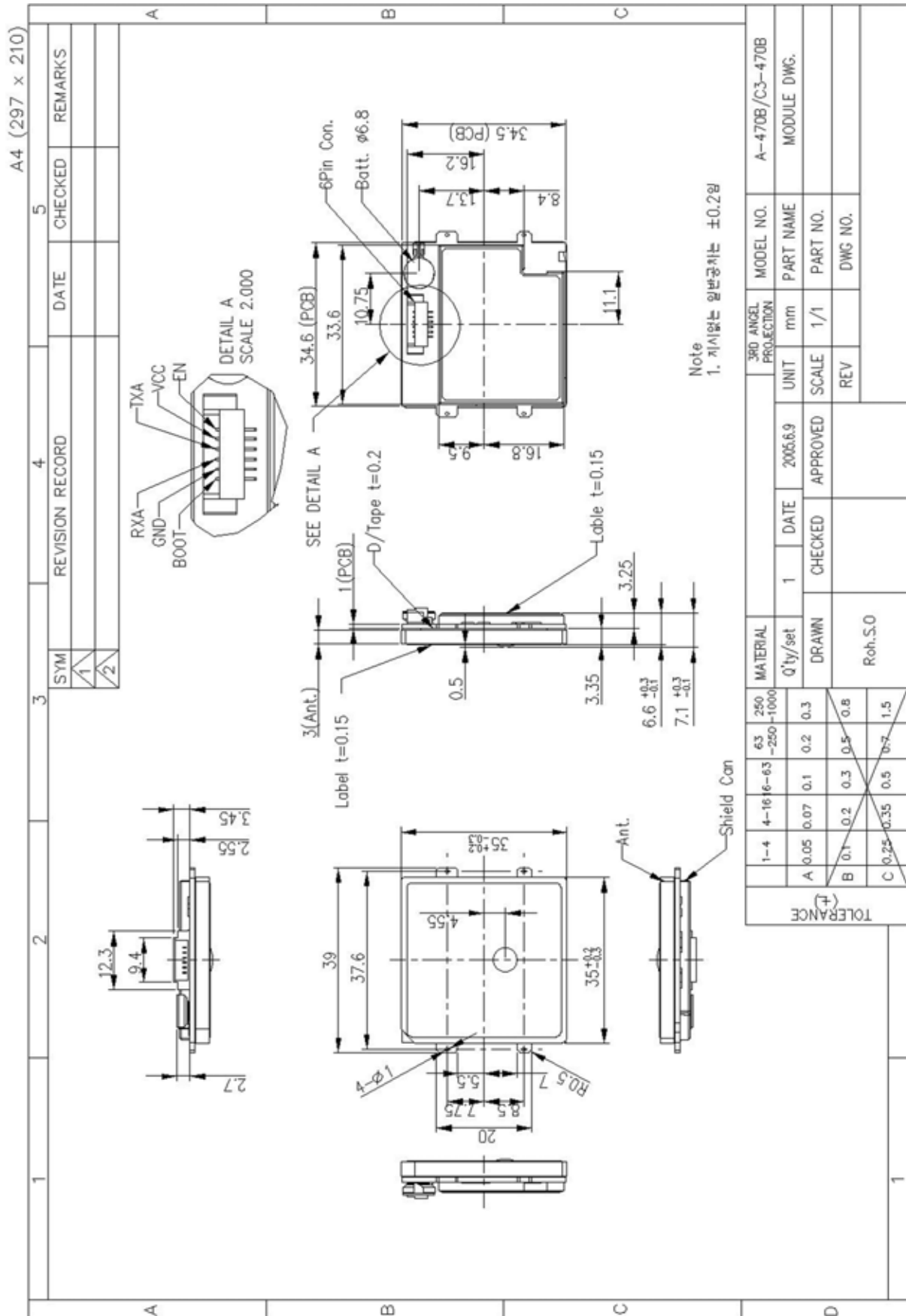

Maker : Yeonho Electronics

# 1.25mm (0.049") PITCH CONNECTOR

Wire-to-Board  
Housing

12505HS Series

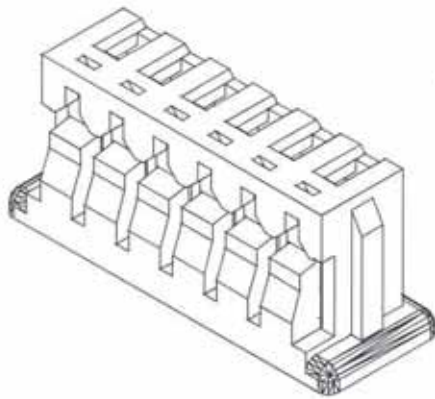

### Material

INO	DESCRIPTION	TITLE	MATERIAL
1	HOUSING	12505HS	PA66, UL 94V Grade

### Available Pin

PARTS NO.	A	B	C
12505HS-02000	4.25	2.95	1.25
12505HS-03000	5.50	4.20	2.50
12505HS-04000	6.75	5.45	3.75
12505HS-05000	8.00	6.70	5.00
12505HS-06000	9.25	7.95	6.25
12505HS-07000	10.50	9.20	7.50
12505HS-08000	11.75	10.45	8.75
12505HS-09000	13.00	11.70	10.00
12505HS-10000	14.25	12.95	11.25
12505HS-11000	15.50	14.20	12.50
12505HS-12000	16.75	15.45	13.75
12505HS-13000	18.00	16.70	15.00
12505HS-14000	19.25	17.95	16.25
12505HS-15000	20.50	19.20	17.50

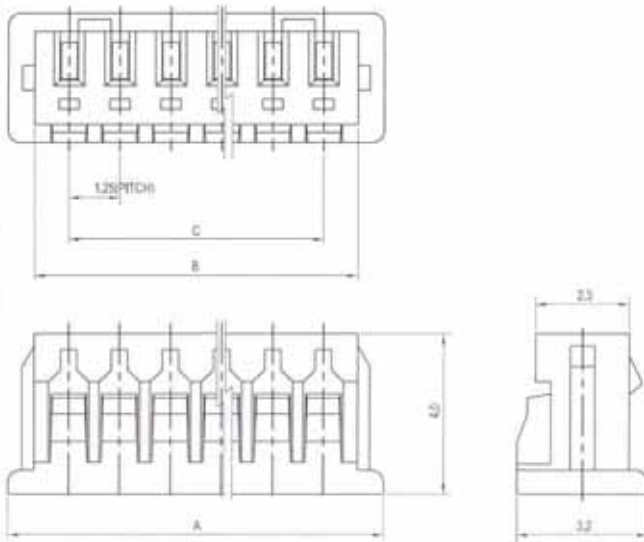

### Specification

ITEM	SPEC
Voltage Rating	AC/DC 125V
Current Rating	AC/DC 1A
Operating Temperature	-25°C~+85°C
Contact Resistance	30mΩ MAX
Withstanding Voltage	AC250V/1min
Insulation Resistance	100MΩ MIN
Applicable Wire	AWG #28~#32
Applicable P.C.B	-
Applicable FPC/FFC	-
Solder Height	-
Crimp Tensile Strength	-
UL FILE NO	E108706

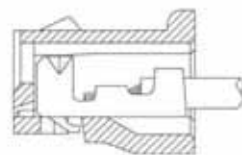

TERMINAL ASSEMBLY DRAWING

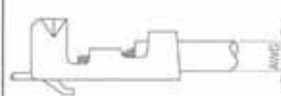

AWG : #28 - #32

Application Terminal : 12505TS (32 Page)

### 6. Packing Description

No.	PARTS NO.	PARTS NAME	REASON FOR REVISION	DATE	APVD
1		BOX CARTON	Out Size (mm) W325*D265*H200	Q'ty/ctn 1/300	Remark DW-1
2		PAD CARTON	315*250*13.0	11/300	SW-1
3		TRAY(부품136-1호)	W310*D248*H14.5	10/300	P.S.t=0.5

**Note**  
1. 인쇄는 삭제될수 있음

<i>Material</i>	DW-1, t=8.0		<i>Title</i>	BOX CARTON
<i>Decimals Tolerance</i>	<i>Date</i> 2005.6.9	<i>Q'ty</i> 300	<i>Item No.</i>	A-470A,B,C/C3-470A,B,C
0~20mm : ±0.05	<i>Scale</i> N/S (A)	<i>Unit</i> mm	<i>Part No.</i>	
21~50mm : ±0.1	<i>Drawing</i>	<i>Checked</i>	<i>Approved</i>	
51~100mm : ±0.15				
101~200mm : ±0.25	<i>Roh.S.0</i>			
201~500mm : ±0.5				
<i>Decimals Tolerance</i> 0.5:				

PACKING

300EA/carton